

SMH-TC Series

SURGE PROTECTION FOR SIGNAL / CONTROL LINES

Main features:

Design:	Replaceable plug-in module 12 mm
Mode of protection:	Longitudinal, Transverse
Coarse Protection:	3 terminal GDT
Available voltages:	5, 12, 15, 24, 30, 48, 60V _{DC} , 110V _{AC}
Freq:	30MHz
Surge Discharge Ratings:	I _n : 10kA 8/20μs I _{max} : 20kA 8/20μs
Load current:	1A
Enclosure:	DIN 43880 2/3TE, DIN rail mount
Terminal:	Multi-strand to 4mm ²

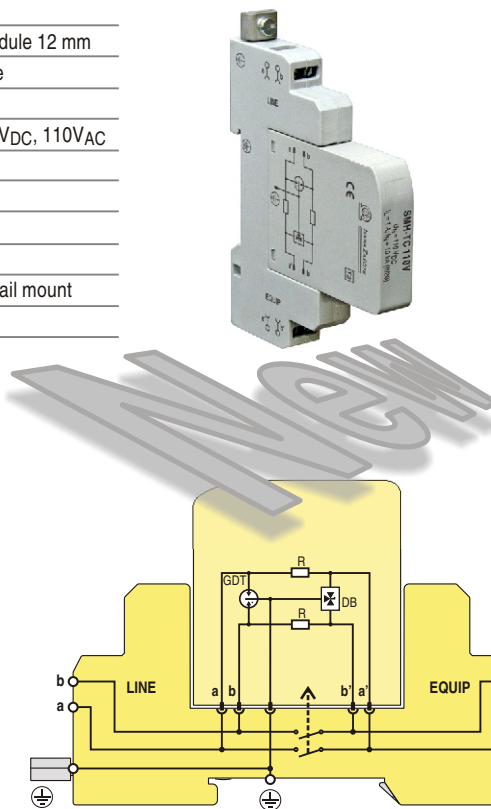
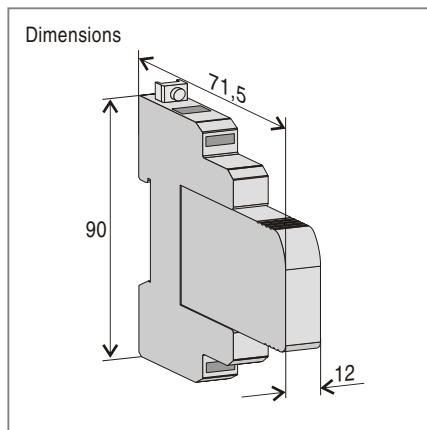

SMH-TC Series Summary:

These efficient overvoltage barriers contain both coarse and fine protection stages and provide longitudinal and a transverse surge protection.

The initial protection stage comprises a three-pole gas discharge tube and is designed to divert the primary surge energy. The subsequent fine protection stage is carried out using fast bi-directional silicon avalanche diodes. Care is taken in the design of this fine protection stage to avoid capacitive line loading and thereby ensuring a low insertion loss and wide operating frequency range.

Series line impedances ensure energy co-ordination between the coarse and a fine protection stages at all levels of the incident surge. To protect against the hazards of electric shock and fire which often results when power frequency contact occurs between power and communication lines (often called mains incursion), a thermo-clip is included on the primary protection stage to divert the power frequency current to ground.

The plug-in module/base design facilitates replacement of a failed module without the need to remove system wiring.

Legend:

GDT	gas discharge tube
R	resistor
DB	diode block

Technical data

Type	SMH-TC								
	110 V	5V	12V	15V	24V	30V	48V	60V	
Protection construction	two parts: base and extractable insert								
Number of protected pairs	1 (2 conductors)								
Nominal operating voltage U _N	110 V _{DC}	5 V _{DC}	12 V _{DC}	15 V _{DC}	24 V _{DC}	30 V _{DC}	48 V _{DC}	60 V _{DC}	
Max. continuous operating voltage U _C	170 V _{DC}	7 V _{DC}	15 V _{DC}	18 V _{DC}	28 V _{DC}	33 V _{DC}	52 V _{DC}	64 V _{DC}	
Rated spark overvoltage (a/b-PG)	184 - 264V	8 - 10V	17 - 21V	21 - 25V	31 - 37V	36 - 44V	57 - 69V	68 - 84V	
(a-b)	184 - 264V	8 - 10V	17 - 21V	21 - 25V	31 - 37V	36 - 44V	57 - 69V	68 - 84V	
Rated operating current I _L at 25°C	1A	1A	1A	1A	1A	1A	1A	1A	
Nominal discharge current I _N (8/20μs)	10kA	10kA	10kA	10kA	10kA	10kA	10kA	10kA	
Max. discharge current I _{MAX} (8/20μs)	20kA	20kA	20kA	20kA	20kA	20kA	20kA	20kA	
Residual voltage at 5 kA (8/20μs)	< 450V	< 22V	< 42V	< 48V	< 70V	< 80V	< 140V	< 160V	
Response time t _A	< 1ns	< 1ns	< 1ns	< 1ns	< 1ns	< 1ns	< 1ns	< 1ns	
Thermal protection	thermo-clip								
Insulation resistance of the protection	≥ 1GΩ / 100V _{DC}	≥ 5KΩ / 5V _{DC}	≥ 12MΩ / 12V _{DC}	≥ 15MΩ / 15V _{DC}	≥ 24MΩ / 24V _{DC}	≥ 30MΩ / 30V _{DC}	≥ 48MΩ / 48V _{DC}	≥ 60MΩ / 60V _{DC}	
Serial resistance R	1.6-2.0Ω	1.6-2.0Ω	1.6-2.0Ω	1.6-2.0Ω	1.6-2.0Ω	1.6-2.0Ω	1.6-2.0Ω	1.6-2.0Ω	
Transverse capacitance C	50pF	50pF	50pF	50pF	50pF	50pF	50pF	50pF	
Limit frequency f _G	30Mhz	30MHz	30MHz	30MHz	30MHz	30MHz	30MHz	30MHz	
Terminal cross section	Multi-strand to 4 mm ²								
Operating temperature	- 40°C ... + 80°C								
Degree of protection	IP 20								
Housing material	Thermoplastic; extinguishing degree V-O								
Dimensions DIN 43880	12mm								
Housing colour	Gray								
Mounting EN 60715	on a 35mm DIN rail								
Ordering code									
Base + Replaceable plug-in module	708 061	708 062	708 063	708 064	708 065	708 066	708 067	708 068	
Replaceable plug-in module	708 051	708 052	708 053	708 054	708 055	708 056	708 057	708 058	